

PLA Channel - Installation Instructions

Please read all instructions prior to installation and keep for future reference!

1. Product should be installed by a qualified electrician.
2. Prior to installation ensure power is off at fuse box to prevent electrical shock.
3. If extrusion is installed facing up and in a wet location, ensure proper drainage and silicone endcaps and diffuser lens.

Page 1 of 2

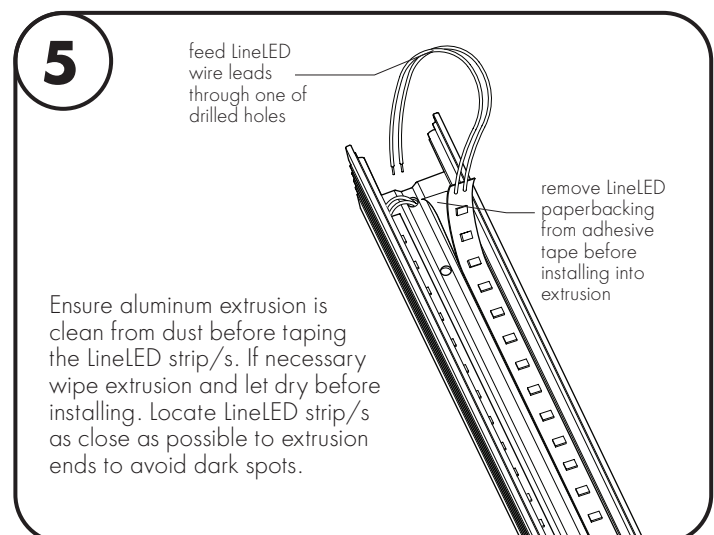
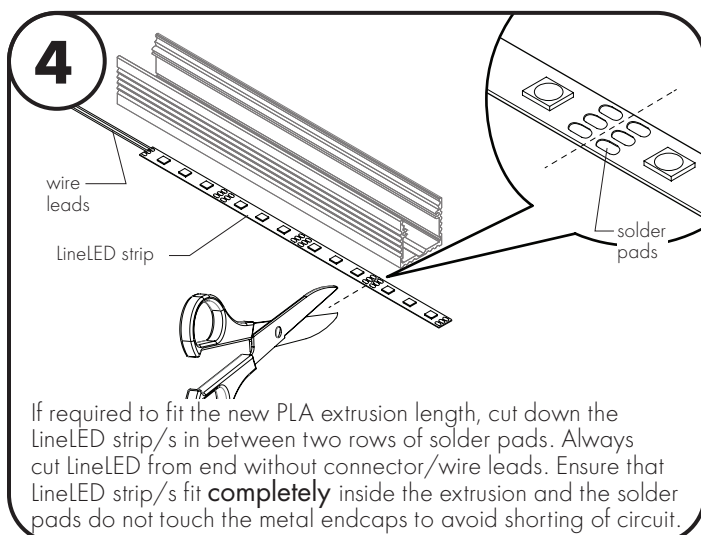
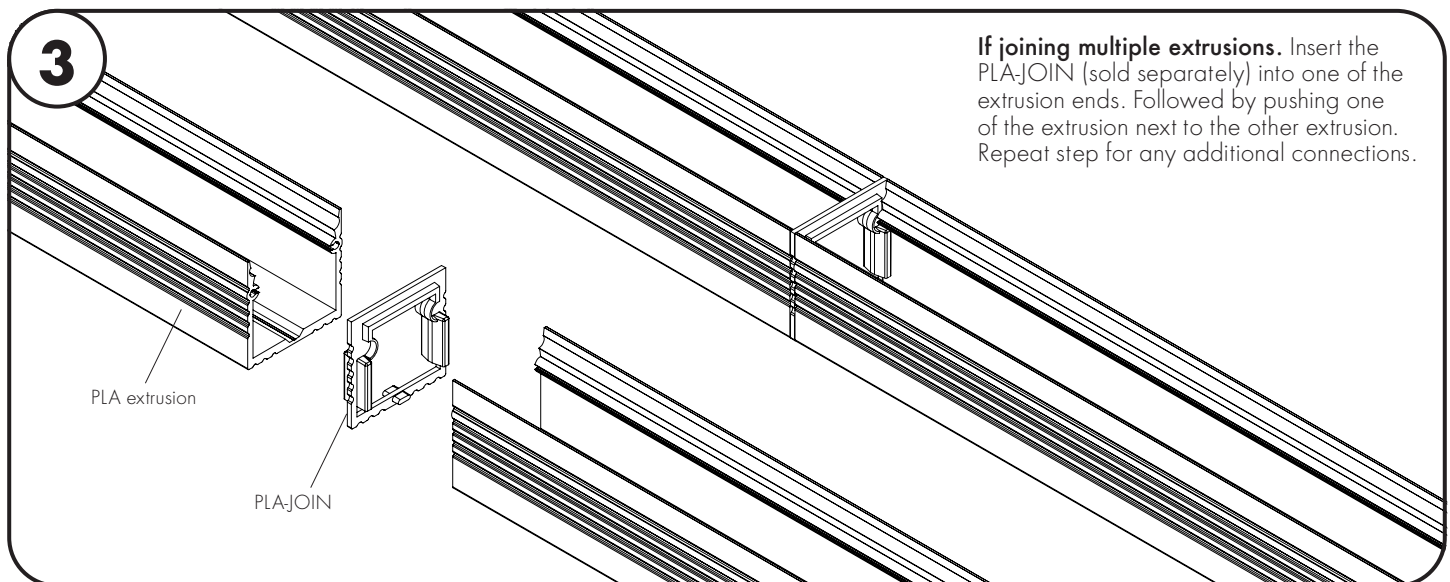
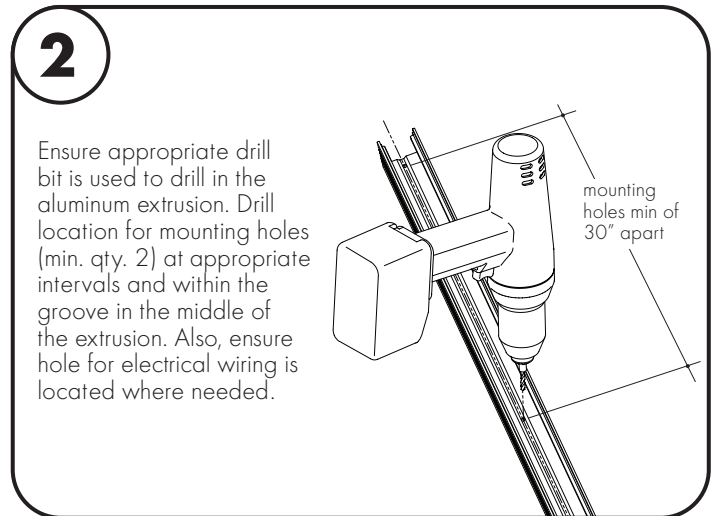
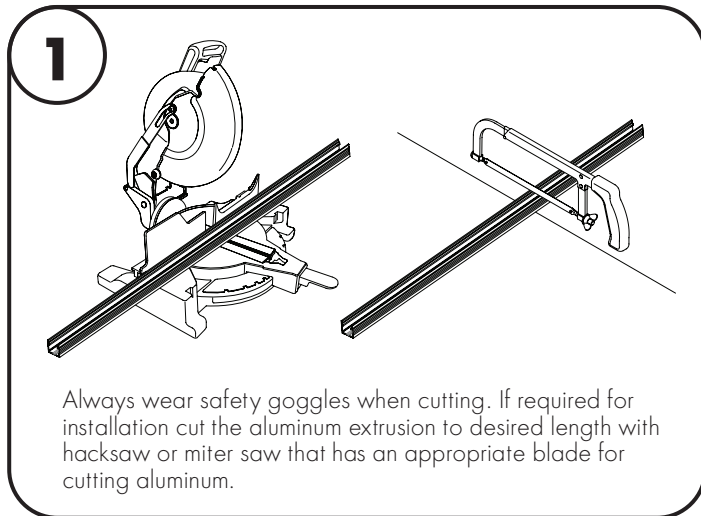

PLA Channel - Installation Instructions



7777 Merrimac Ave
Niles, IL 60714
T 224.333.6033
F 224.757.7557
info@luminii.com
www.luminii.com

Please read all instructions prior to installation and keep for future reference!

1. Product should be installed by a qualified electrician.
2. Prior to installation ensure power is off at fuse box to prevent electrical shock.
3. If extrusion is installed facing up and in a wet location, ensure proper drainage and silicone endcaps and diffuser lens.

