

# LineLED 24V - Installation Instructions

Models LL60X2 WETT



7777 Merrimac Ave  
Niles, IL 60714  
T 224.333.6033  
F 224.757.7557  
info@luminii.com  
www.luminii.com

REVO.3  
07182023

1 / 1

Please read all instructions prior to installation and keep for future reference!

1. PRODUCT SHOULD BE INSTALLED BY A QUALIFIED ELECTRICIAN
2. ENSURE POWER IS OFF AT FUSE BOX PRIOR TO INSTALLATION TO PREVENT ELECTRICAL SHOCK.
3. USE ONLY WITH CLASS 2 POWER UNIT
4. SUITABLE FOR DAMP LOCATIONS
5. FOR UNDER CABINET OR SHELF MOUNT
6. CONFORMS TO UL STD 2108. CERTIFIED TO CSA STD C22.2 NO.250.0.

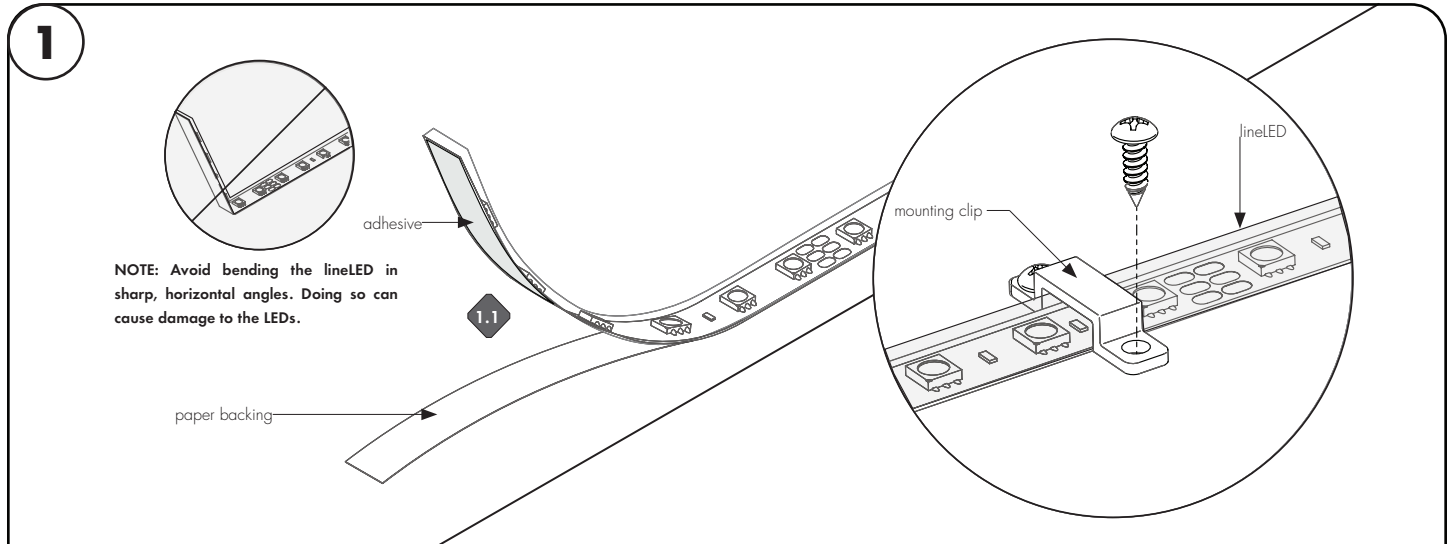

NOTE: Avoid bending the lineLED in sharp, horizontal angles. Doing so can cause damage to the LEDs.

- 1.1 Clean the area thoroughly where the lineLED will be installed. Remove the paper backing from the lineLED and firmly press down making sure there are no air bubbles that can cause surface irregularities. Do not remove the adhesive, removing the adhesive may cause arcing of the lineLED tape.
- 1.2 If necessary, add a mounting clip every 12" for additional support.

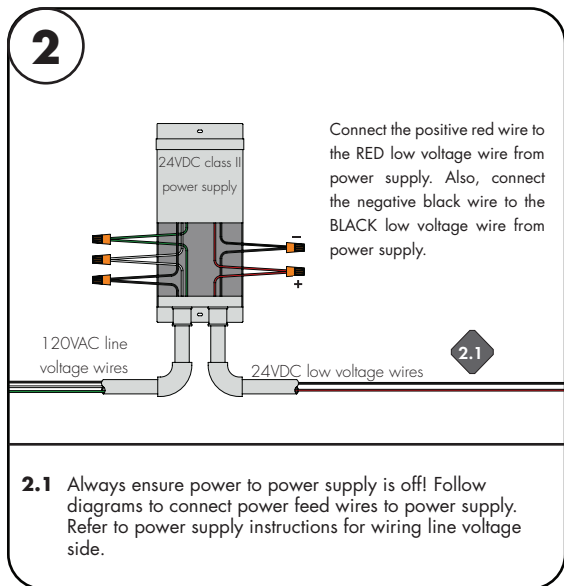

Connect the positive red wire to the RED low voltage wire from power supply. Also, connect the negative black wire to the BLACK low voltage wire from power supply.

- 2.1 Always ensure power to power supply is off! Follow diagrams to connect power feed wires to power supply. Refer to power supply instructions for wiring line voltage side.